

THE EXPERT CHOICE
FOR SAFETY AND
LOWER LIFECYCLE COST.
**STAINLESS STEEL
CHEQUERED SHEETS**

JINDAL INFINITY

164x
CORROSION
RESISTANCE

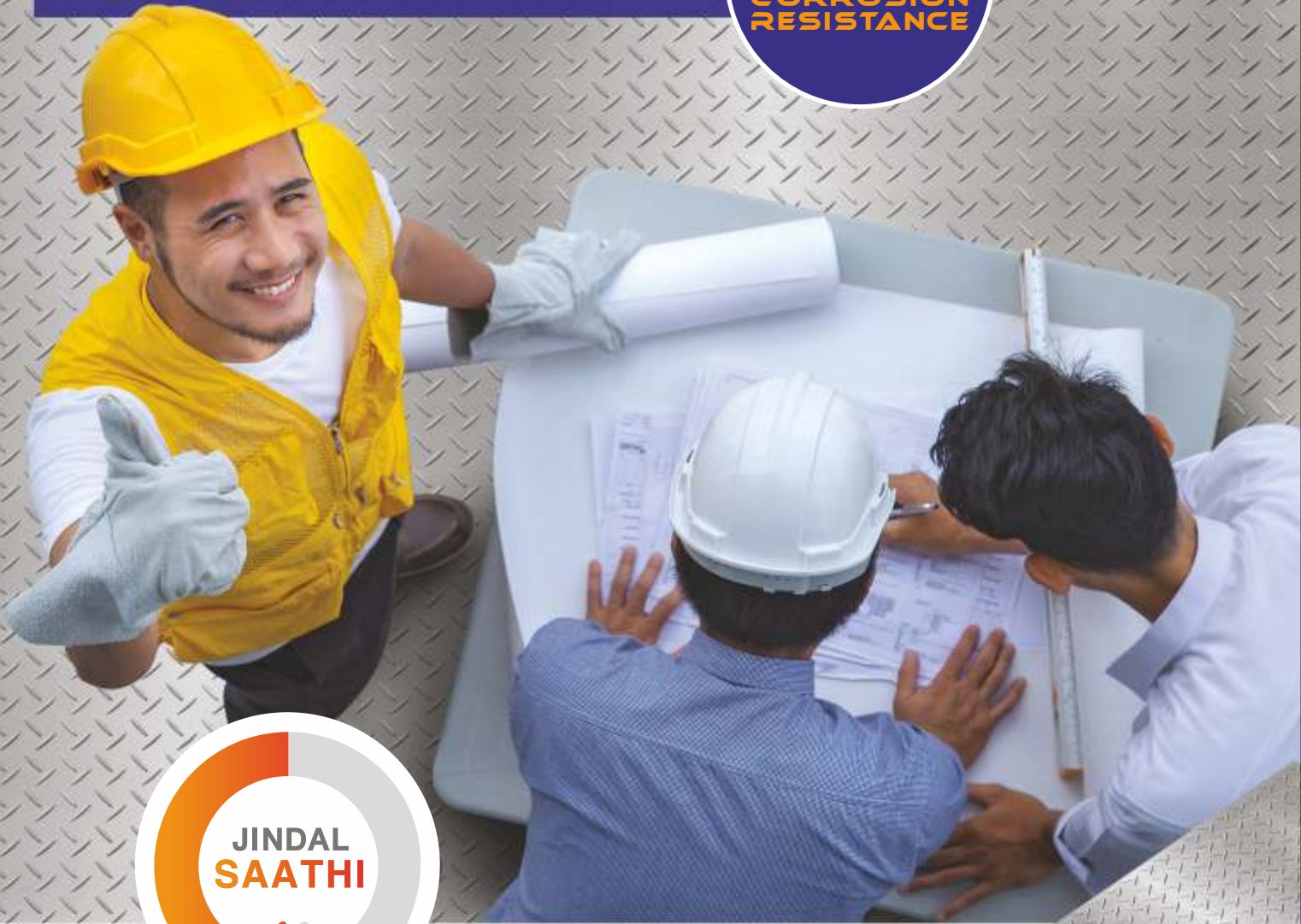

PROMISE



Corrosion
Resistance



Slip
Resistance



Low
Maintenance Cost



Wear
Resistance



Easy Malleability
& Ductility



THE METAL OF CHOICE

LOW MAINTENANCE FOR HIGH PROFITABILITY

Created from 409M stainless steel

Unparalleled corrosion resistance, wear resistance and enhanced safety

Superior aesthetics, hygiene and longer lifecycle perfect for every type of environment

The Edge of Efficiency and Safety stands with stainless steel

Stainless steel is an alloy of iron with a minimum of 10.5% chromium. Stainless steel is protected from corrosion by a thin layer of chromium oxide. Oxygen from the atmosphere combines with the chromium in stainless steel to form this passive chromium oxide film that protects from further corrosion.

Stainless Steel Hot Rolled Annealed & Pickled Chequered Sheet, also known as Checker Sheet, features a continuous pattern of raised diamonds on one side for enhanced walking safety. The other side has a smooth surface for ease of fabrication.

The leading choice that's built to last

SS 409M

HRAP Chequered



Mild Steel

HR Chequered



THE JINDAL STAINLESS ADVANTAGE

PARAMETERS	MS (IS2062)	SS (409M)	BENEFITS OFFERED
Corrosion Resistance	Low	High	Longer life than MS, as per the CSIR study.
Yield Strength	250 MPA	350 MPA	30% weight reduction due to lower thickness.
Wear Rate	62	13	5 times higher wear resistance
Maintenance	High	Low	No painting required

164 TIMES MORE CORROSION RESISTANT 1 LASTING PROMISE.

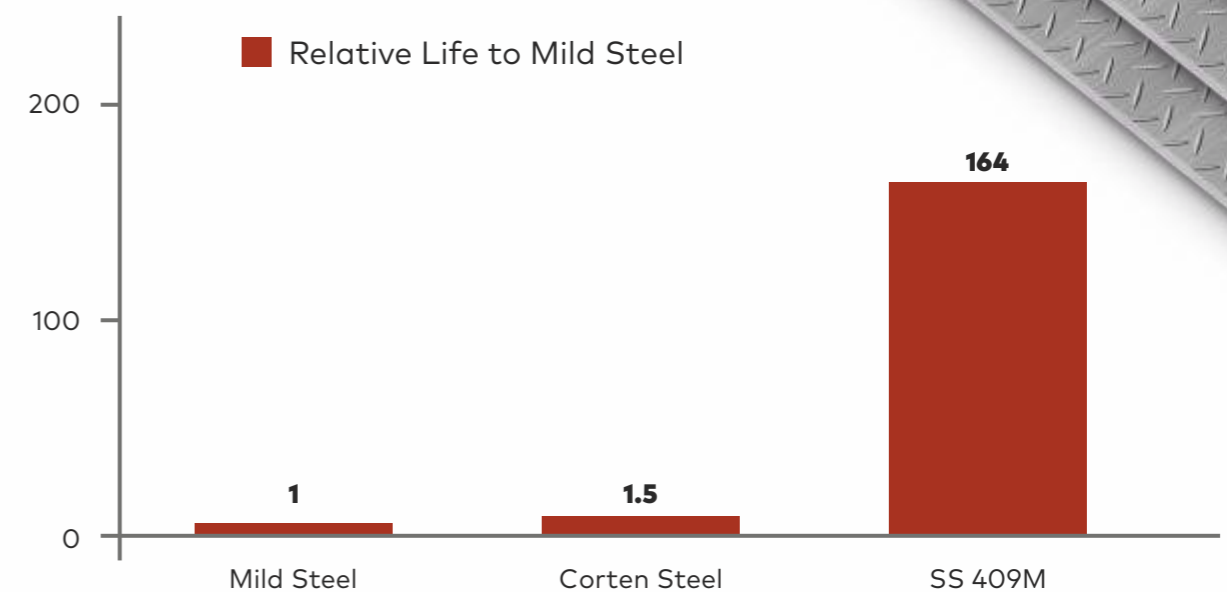

This graph is taken from a report 'Atmospheric corrosion testing in Southern Africa-Results of a twenty year exposure programme' conducted by BG Callaghan, Division of Materials Science and Technology, CSIR (South Africa).

30% Lighter Weight with Higher Durability

Mild Steel	Thickness in MS (mm)	3	4	5	6
	Per Sq. Mtr. Weight (Kg)	23.7	31.6	39.5	47.4
SS 409M	Suggested Thick. In SS (mm)	2.8	2.8	3.5	4.2
	Per Sq. Mtr. Weight (Kg)	22.1	22.1	27.7	33.2
Weight Reduction	% Reduction	-7%	-30%	-30%	-30%

UP TO 5 TIMES HIGHER WEAR RESISTANCE FOR HIGHER COST SAVINGS

Grade 409M is known for its high wear resistance. Under the sliding wear test condition grade 409M is 1.6 times better than HSLA steel and 4.7 times better than normal mild steel.

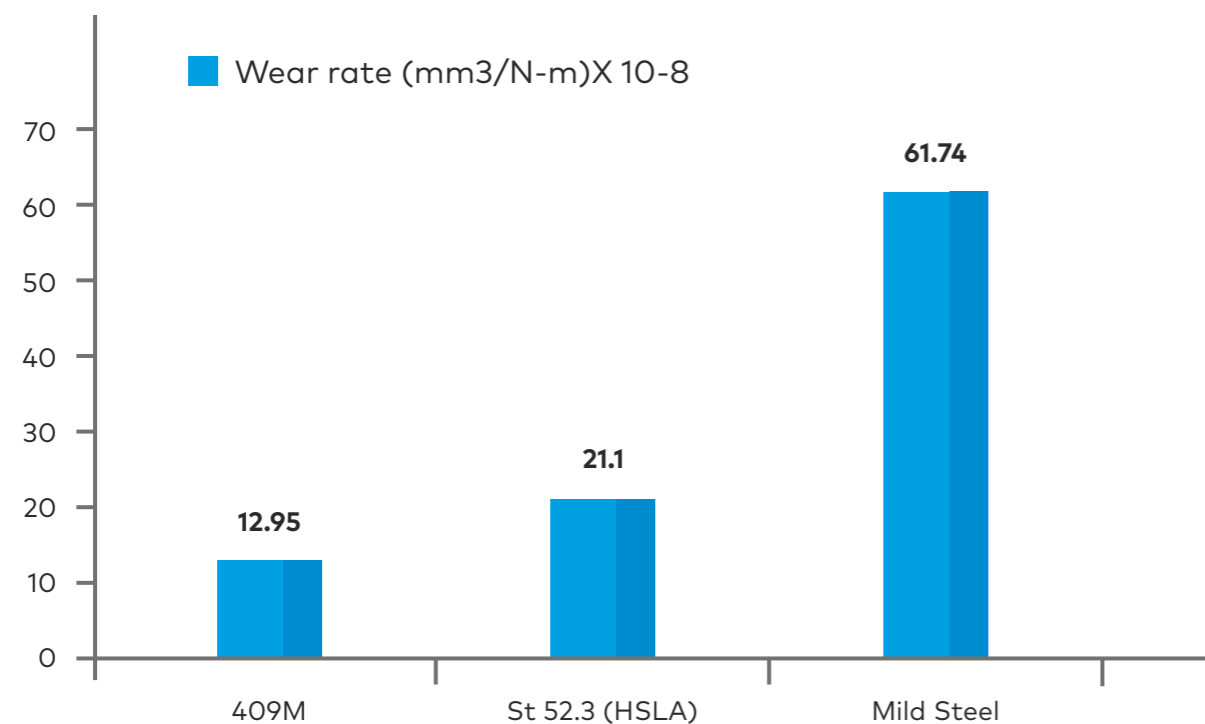

INNOVATED FOR A STRONG & LONG-LASTING FUTURE Product Range



Chemical Composition

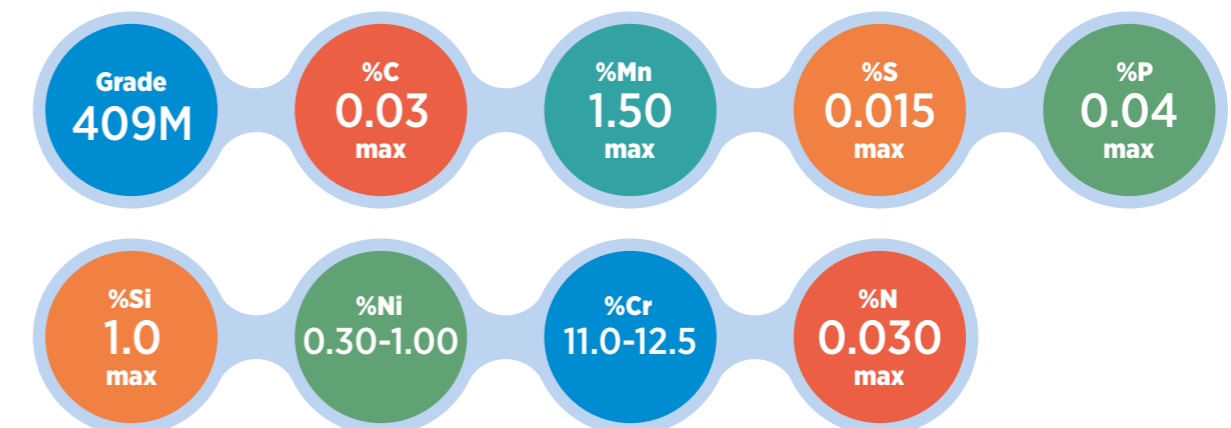

Mechanical & Physical Properties

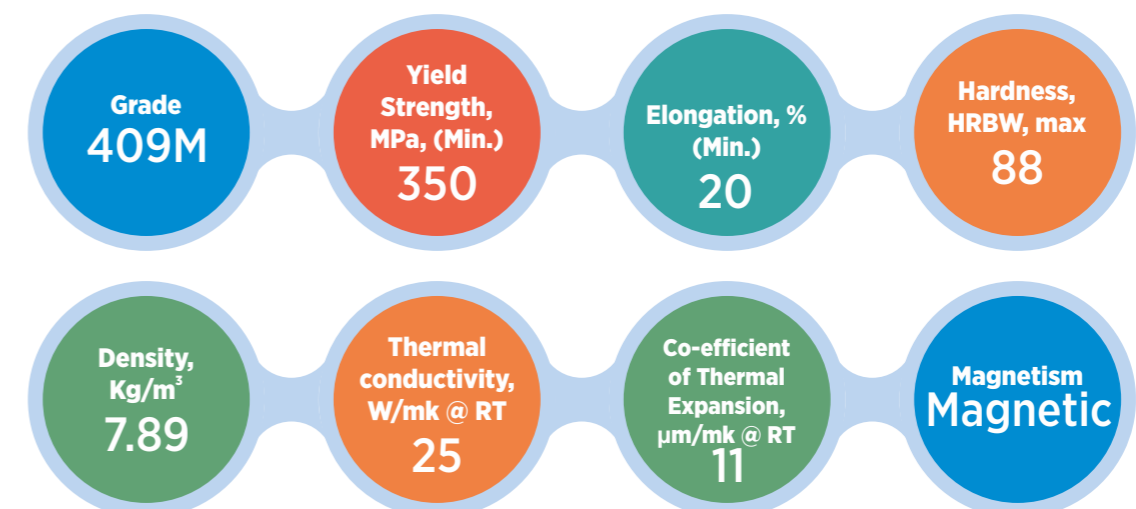

PATTERNED ALONG THE BEST GLOBAL STANDARDS

The pattern of Jindal Stainless Steel Chequered Sheets is in accordance with IS 3502 Pattern 1A.

Dimensions of Bead*

- Length – 27mm
- Width – 8mm
- Height – 0.70 to 1.10mm

Number of Beads*

- (100mm x 100mm):11
- *Standard tolerance applies

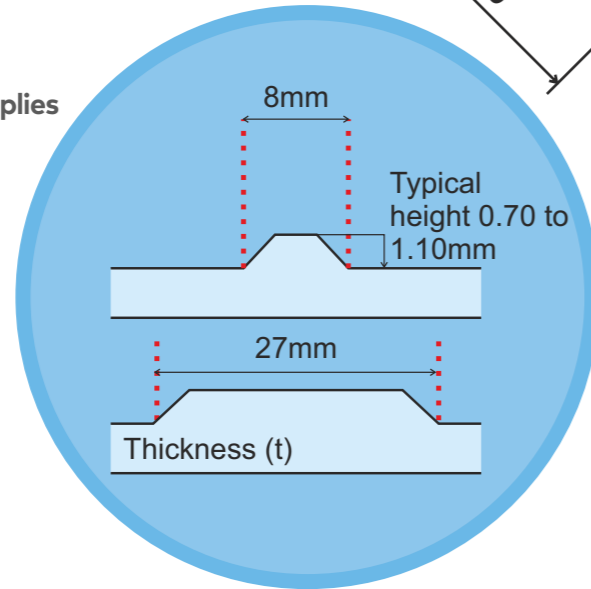
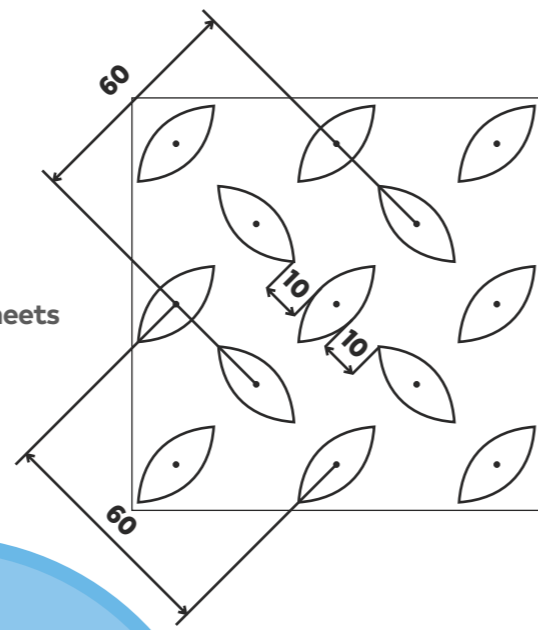

Lower Lifecycle Cost for a Lifetime of Growth

LCC of SS 409M HRAP Chequered vs Mild Steel HF Chequered Over 30 Years Life

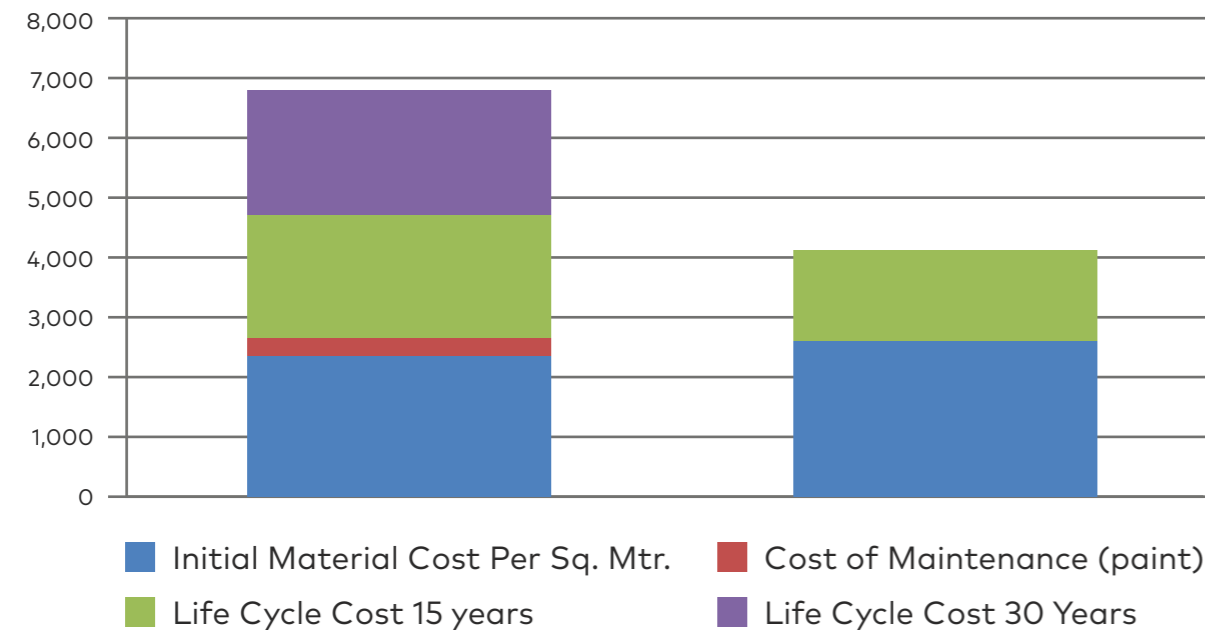

CHOOSE SAFETY THAT IS LONG-LASTING WITH JINDAL STAINLESS CHEQUERED SHEETS

164x CORROSION RESISTANCE

THE PROMISE OF PROGRESS STRENGTHENED BY SAFER AND RELIABLE

JINDAL STAINLESS CHEQUERED SHEETS



Railway Bridge Pathway: Ensuring safety & convenience during maintenance and inspections.



Bus-Truck/Steps & Floors with wear resistance and enhanced durability

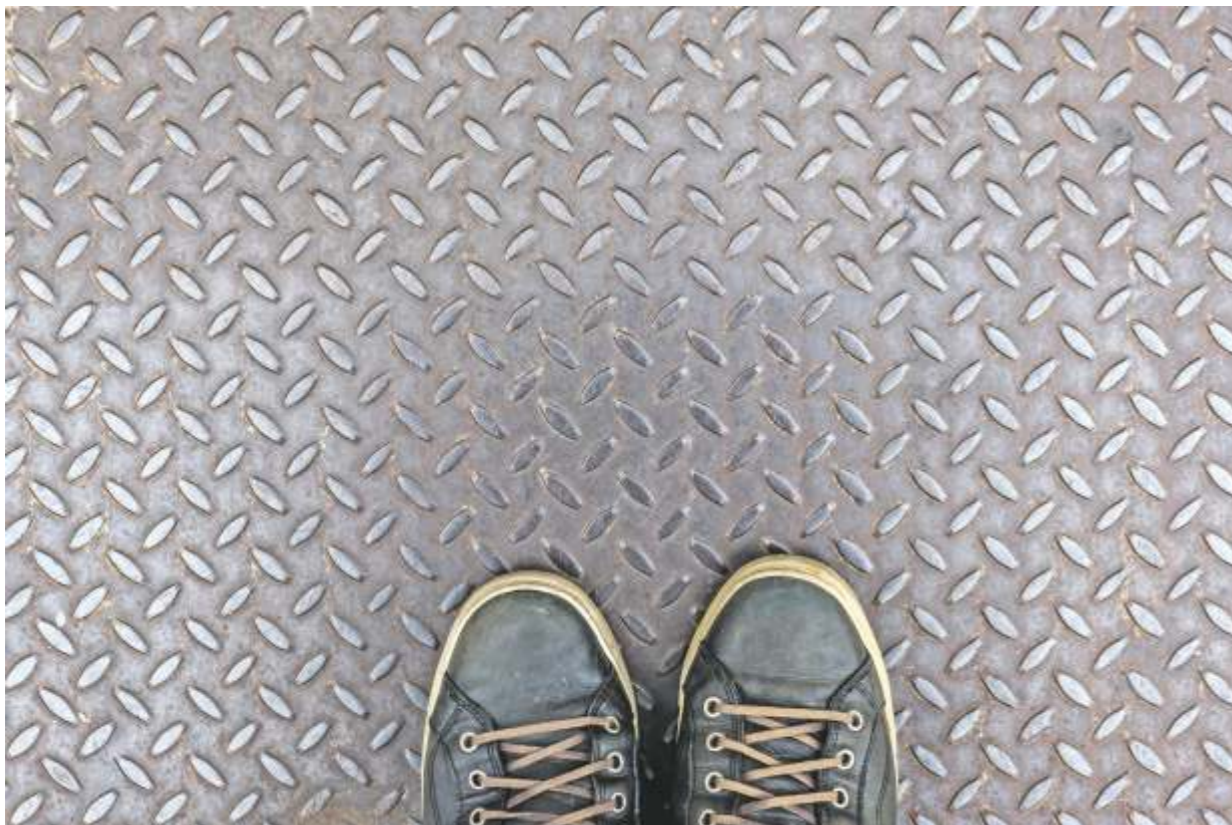

Flooring, Stairs and Counters in Pharmaceutical & Food Plants
with high resistance to corrosion and heat



Architectural Stairs & Flooring with a lustrous finish and high aesthetic appeal



THE FOUNDATION OF SUCCESS WITH JINDAL STAINLESS

Founded by Shri O.P. Jindal in 1970, Jindal Stainless is one of the largest stainless steel conglomerates in India and ranks amongst the top 10 stainless steel conglomerates in the world. Jindal Stainless group has an annual crude steel capacity of 1.9 MTPA and an annual turnover of US \$2.70 billion. It is equipped with state-of-the-art machinery, producing output comparable to global standards. The skilled manpower resources, with decades of expertise, ensure execution excellence. Stainless Steel Chequered Sheets - developed through its world-class R&D facility - ensure superior performance across diversified applications.



East: Rishi Kumar Bajpai
rishi.bajpai@jshl.in
9996619560

Jindal Stainless Ltd.
3A, Duckback House,
Shakespear Sarani Road,
Kolkata - 700017

South: Kadithi Avish
kadithi.avish@jindalstainless.com
9909947036

Jindal Stainless Centre
"HEVITREE", 1st Floor, No.47,
Spurtank Road, Chetpet 600031

West: Jaswant Singh Bisht
jaswant.bisht@jindalstainless.com
7777025985

Jindal Stainless Ltd.
Jindal Mansion, 1st Floor, 5A,
G.Deshmukh Marg (Pedder Road)
Mumbai - 400026

North: Manoj Bhutani
manoj.bhutani@jindalstainless.com
8826818981

Jindal Stainless Centre
Stainless Centre, 1st Floor,
Plot No-50, Sector 32,
Gurugram - 122001

email: durasafe@jindalstainless.com

www.jindalstainless.com

Contact Mr. Nagarajan P

8130757806

for any technical consultancy and
participation in seminars

visit www.makestainless.com for suppliers

of consumables, fasteners and fabricated components.